

TOP825-GAL-PE-RT

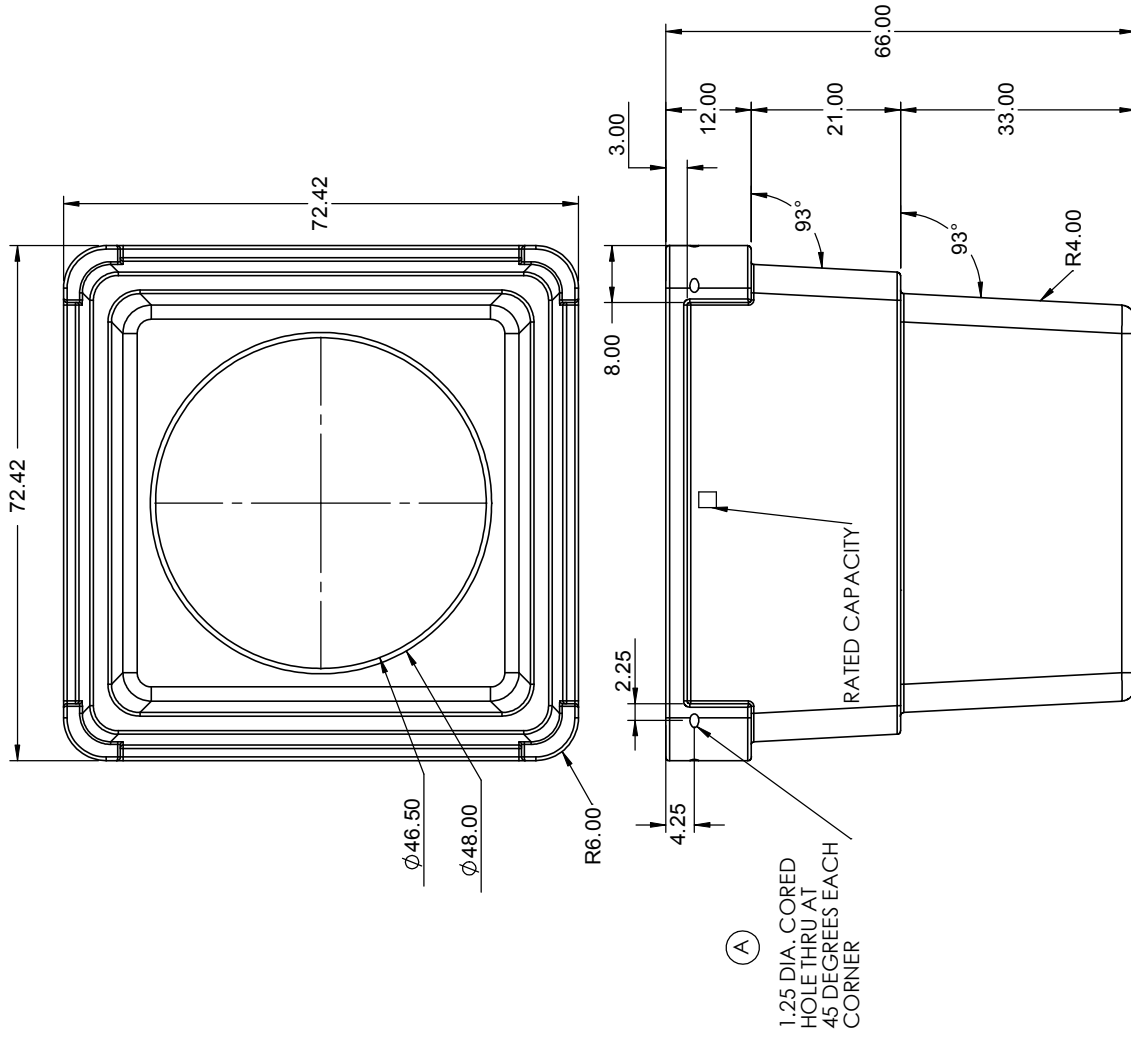

STACK 5 HIGH UPSIDE DOWN FOR STORAGE

<p><b>CSI</b> ChemIndustrial Systems, Inc. PO Box 500, Cedarburg, WI 53012 262-375-8570 • (Fax) 262-375-8559 • info@chemindustrial.com</p>		<p>825 GALLON CONTAINMENT TANK</p>	
<p>DESCRIPTION</p>		<p>PART NO.</p>	
<p>SCALE</p>		<p>TOP825-GAL-PE-RT</p>	
<p>DRAWN / DATE</p>		<p>MATERIAL</p>	
<p>ADH 6/25/08</p>		<p>10538 POWDER.</p>	
<p>APPRD. / DATE</p>		<p>NOTES:</p>	
<p>REH 7/1/08</p>		<p>1. NATURAL COLOR STD.</p>	
<p>BY / DATE</p>		<p>2. .350 WALL THICKNESS</p>	
<p>1775</p>		<p>SHOT WEIGHT: 288 LB.</p>	
<p>CCN</p>		<p>SHIPPING WEIGHT: 276 LB.</p>	
<p>ANSI 14.5M</p>		<p>FINISH: BEAD BLAST</p>	
<p>REH 1/5/09</p>		<p>+</p>	
<p>DESCRIPTION</p>		<p>+</p>	
<p>ALL DIMENSIONS ARE IN DECIMAL INCHES TOLERANCES UNLESS OTHERWISE SPECIFIED</p>		<p>+</p>	
<p>POLYETHYLENE</p>		<p>+</p>	
<p>±1% @ 68°F</p>		<p>DECIMAL ± .125" FRACTION ± 1/4" ANGLE ± 1°</p>	