

BOTTOM VIEW OF TANK

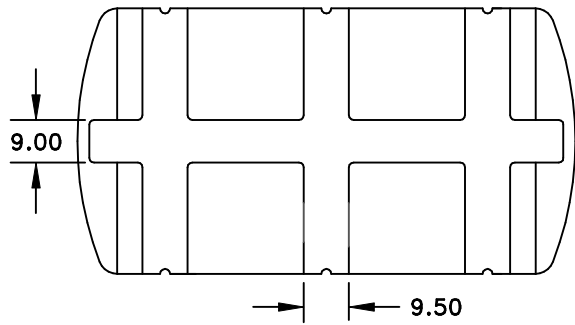

ø4.50 CENTER OPENING
ø16" FILLWELL

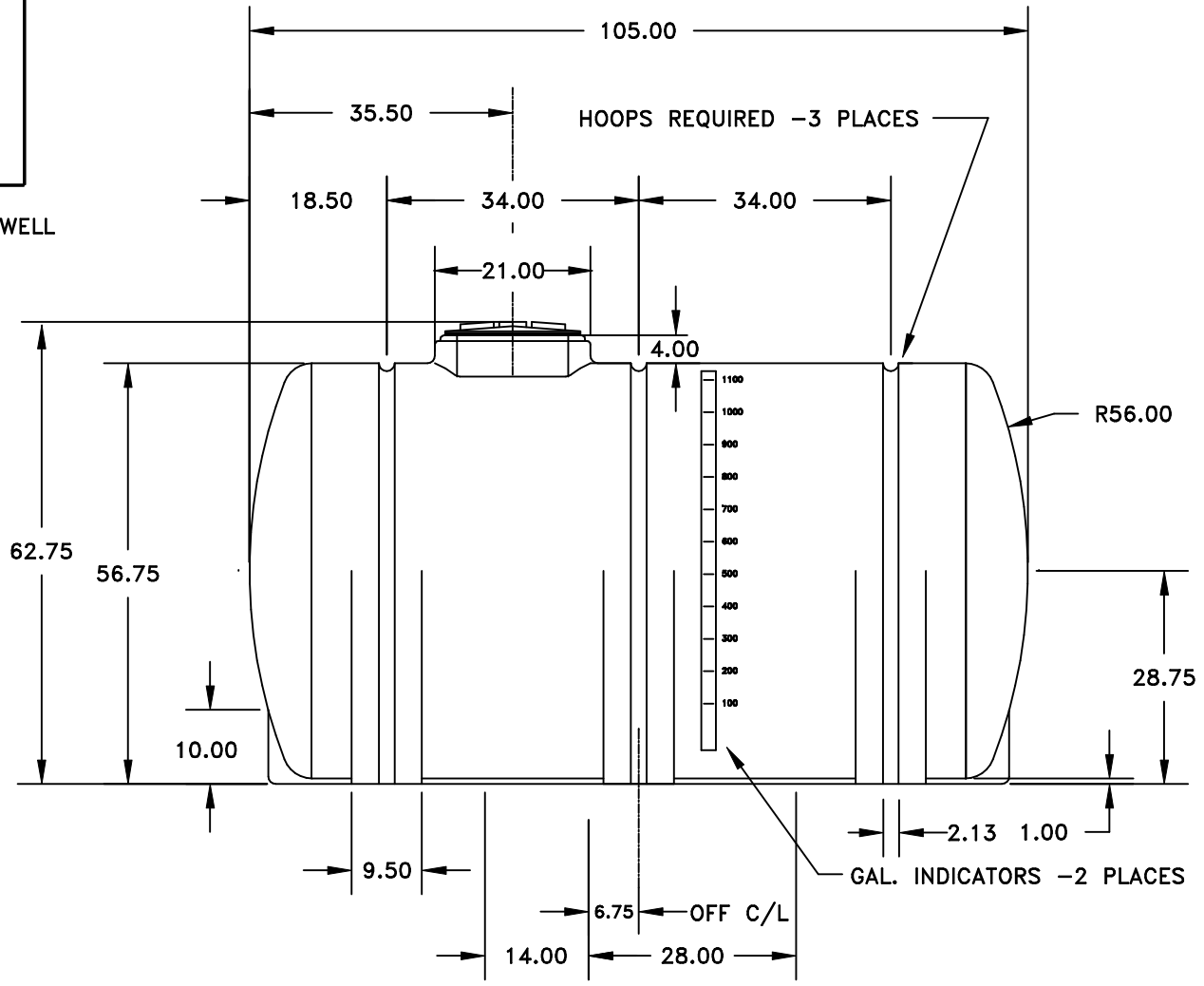
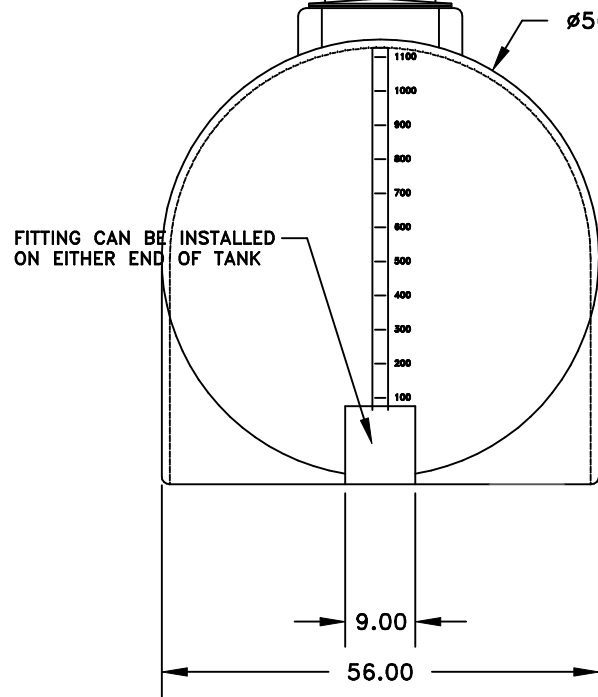

A	WAS FS1065-58	3/23/06	
REV	DESCRIPTION	DATE	APPRD

DRAWN / DATE	REH/1/30/96
APPRD. / DATE	REH/1/30/96

MATERIAL / SHOT WEIGHT			
M111	M135	U625	P938
	300		

ALL DIMENSIONS ARE IN DECIMAL INCHES
TOLERANCES UNLESS OTHERWISE SPECIFIED
+ .5% ● 68° F

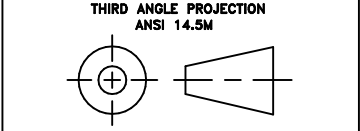

- NOTES:
1. NOM. WALL = .375
 2. SHRINK ALLOWANCE = 2.75%
 3. RESIN IS NATURAL COLOR
 4. FDA APPROVED RESIN
 5. U.V. STABILIZED



ChemIndustrial Systems, Inc.
PO Box 500, Cedarburg, WI 53012
262-375-8570 • (Fax) 262-375-8559 • info@chemindustrial.com

SCALE	N.S.	PART NO.
-------	------	----------