

STANDARD LID IS 8"

GALLON / LITER INDICATORS ONE SIDE AND ONE END.
GALLON CALIBRATIONS ARE IN 25 GAL. INCREMENTS

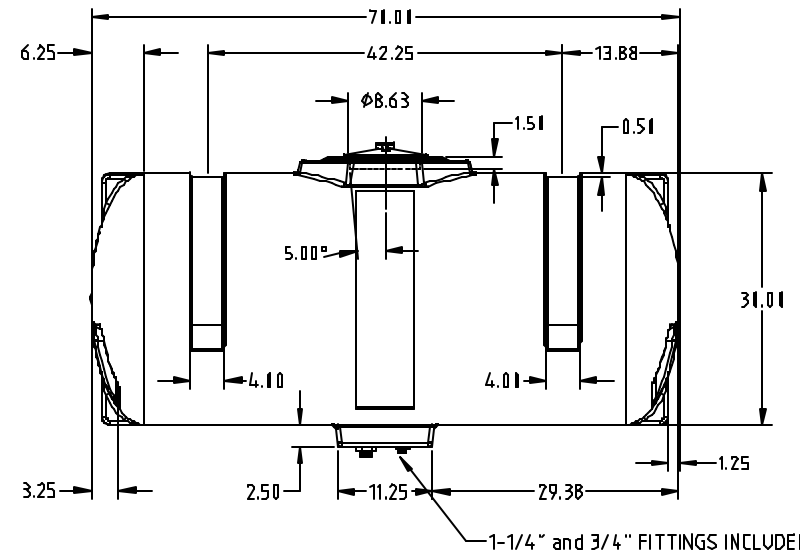
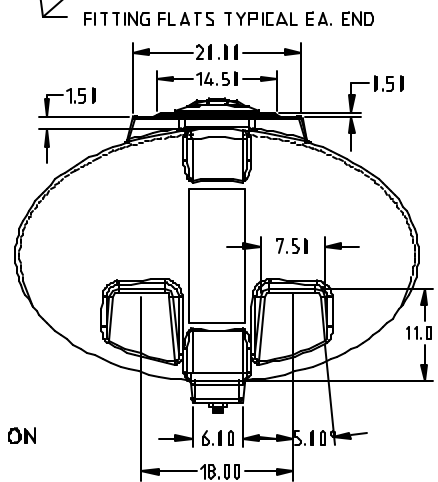

GENERAL NOTES:

1. USE .027 IN./IN. SHRINK ALLOWANCE
2. MOLD TO BE FULLY WELDED INSIDE AND STITCH WELDED OUTSIDE
3. CLAMPING TO BE WITH 1/2" X 1-1/2" GRADE 8 BOLTS, GRADE 5 NUTS AND NUT HOLDERS.
4. LID RING RECESS TO HAVE KNIFE EDGE ON INSERT TO MINIMIZE TRIMMING.

		DRAWN / DATE		MATERIAL / SHOT WEIGHT			
		REH/4/8/01		M111	M134	U625	P938
		APPRD. / DATE		NOTES:			
		REH/4/08/01		1. .300 NOMINAL WALL			
REV	DESCRIPTION	DATE	APPRD				
ALL DIMENSIONS ARE IN DECIMAL INCHES TOLERANCES UNLESS OTHERWISE SPECIFIED $\pm .5\% \text{ @ } 68^\circ \text{ F}$							

CSI
ChemIndustrial Systems, Inc.
PO Box 500, Cedarburg, WI 53012
262-375-8570 • (Fax) 262-375-8559 • info@chemindustrial.com

SCALE	N.S.	PART NO.
-------	------	----------