

KEY	PART NUMBER	DESCRIPTION	QTY.
1	A01250X15000	1/8 X 1 1/2 ANGLE	200 IN
2	B02500X30000	1/4 X 3 FLAT	306 IN (6 @ 51)
3	B03750X20000	3/8 X 2 FLAT	288 IN (6 @ 48)
4	C03X4.1	3" CHANNEL	576 IN
5	P10000	1" PIPE	217.5 IN (6 @ 36.25)
6	S-14GA	14 GA SHEET	9999 SI, (3 @ 48 X 88)
7	SJCB86/90ST-1	12" CB RING STAND	1
8	SJCB86/90ST-7	1/4 X 4 X 4 LEG PAD	6
9	T1000X01090	1 OD X .109 TUBING	241.5 IN (6 @ 40.25)

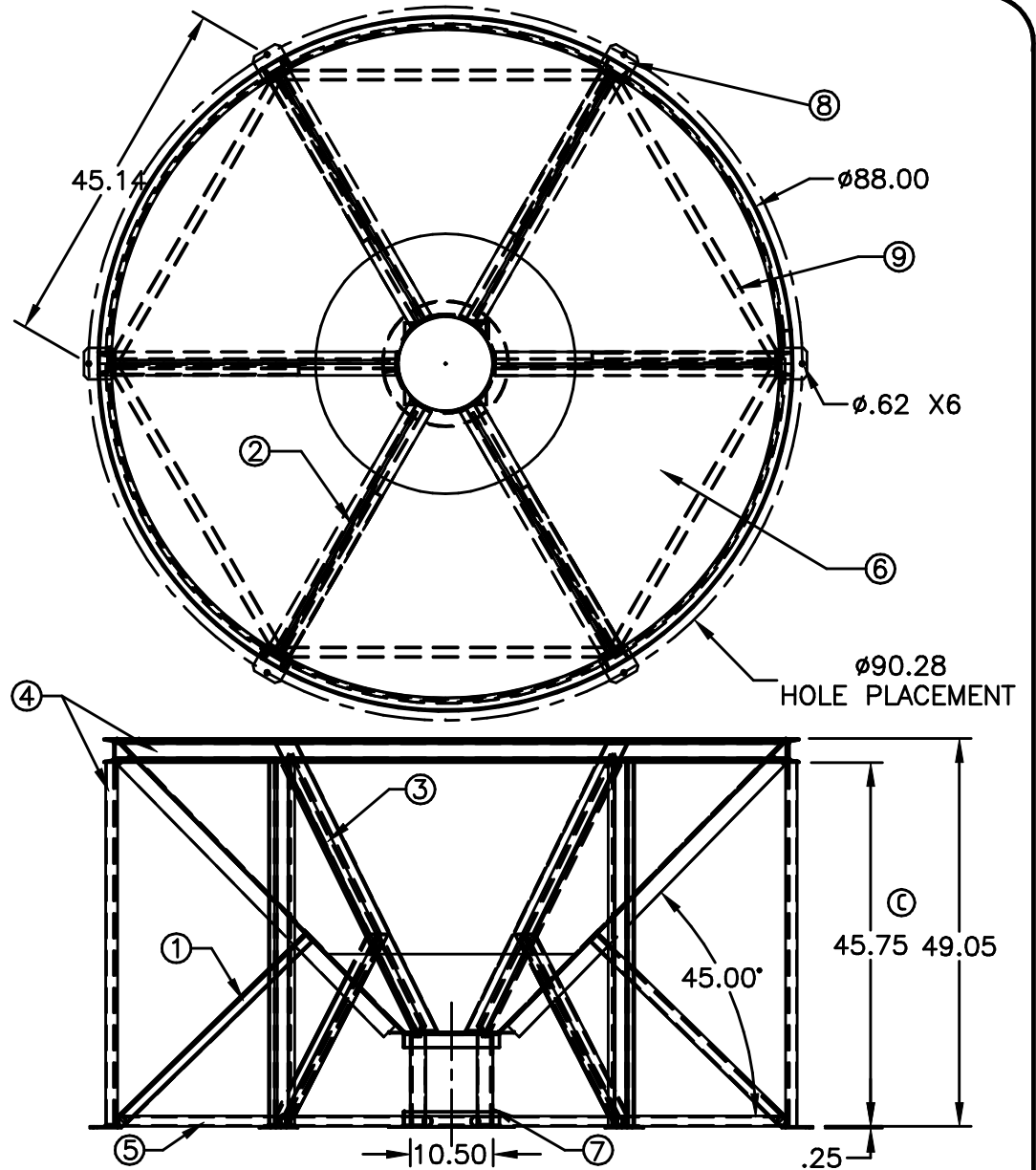
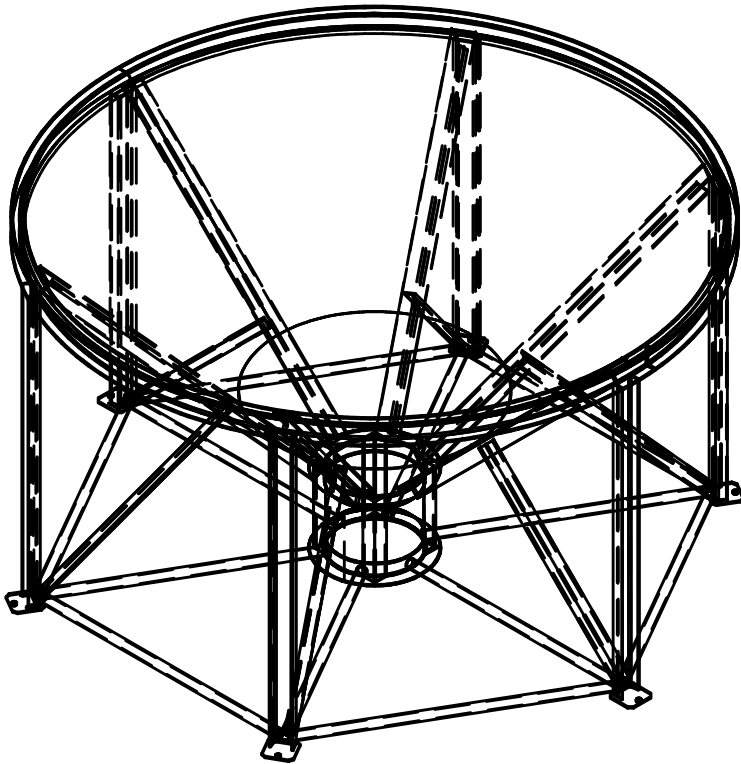

C	WAS 46.00	12/27/06		DRAWN / DATE	
B	PN WAS CB085-45ST	7/31/06	NVE	NVE 7/1/05	
A	ADDED B.O.M.	6/9/06	NVE	APPRD. / DATE	
REV	DESCRIPTION	DATE	APPRD	DHJ 10/14/05	

MATERIAL	
MILD STEEL	

NOTES:

- POWDER COATED - BLACK COLOR
- WEIGHT 580 LBS.

CSI
ChemIndustrial Systems, Inc.
PO Box 500, Cedarburg, WI 53012
262-375-8570 • (Fax) 262-375-8559 • info@chemindustrial.com

SCALE: N.S. PART NO.:

ALL DIMENSIONS ARE IN DECIMAL INCHES
TOLERANCES UNLESS OTHERWISE SPECIFIED
± 0.25

