

KEY	PART NUMBER	DESCRIPTION	QTY.
1	B03750x20000	3/8 X 2 MILD STEEL FLAT	141 IN, (4 @ 35.25)
2	C03X4.1	3" MILD STEEL CHANNEL	400.50 IN
3	P10000	1" SIZE TUBING	211.5 IN, (6 @ 35.25)
4	S-14GA	14 GA MILD STEEL SHEET	8448 SI, (2 @ 48" X 88")
5	SJCB86/90ST-1	12" CONE BOTTOM RING STAND	1
6	SJCB86/90ST-7	1/4" X 4" X 4" LEG PAD	6

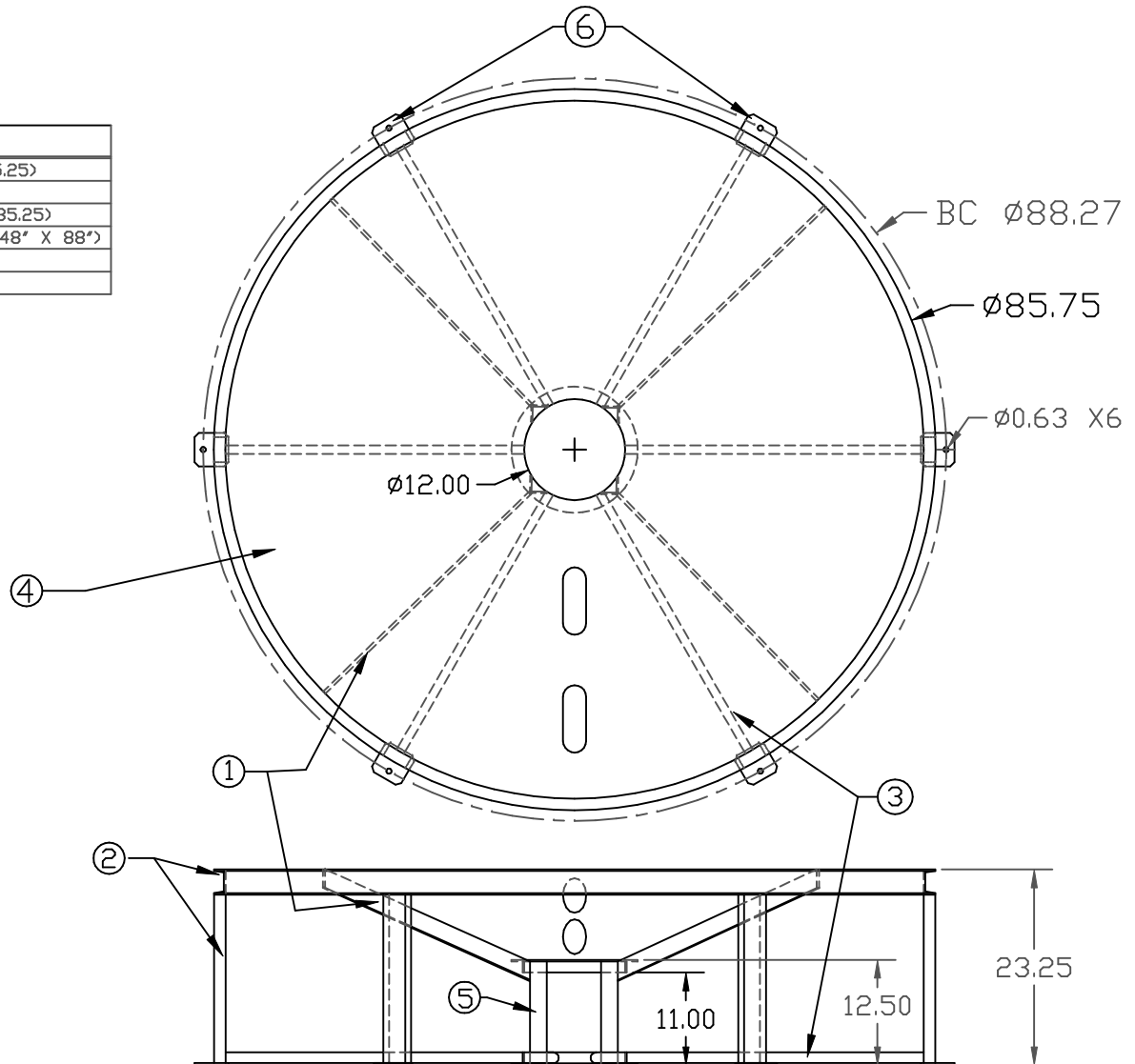

				DRAWN / DATE		MATERIAL	
B	PN WAS CB085-15ST	7/31/06	NVE	DHJ 4/13/04		MILD STEEL	
A	ADDED B.O.M.	5/17/06	NVE	APPRD. / DATE			
REV	DESCRIPTION	DATE	APPRD				
ALL DIMENSIONS ARE IN DECIMAL INCHES TOLERANCES UNLESS OTHERWISE SPECIFIED ± 0.25				THIRD ANGLE PROJECTION ANSI 14.5M 		NOTES: 1. BLACK COLOR - POWDER COATED 2. WEIGHT 360 LBS.	



ChemIndustrial Systems, Inc.
 PO Box 500, Cedarburg, WI 53012
 262-375-8570 • (Fax) 262-375-8559 • info@chemindustrial.com

SCALE N.S.	PART NO.
---------------	----------