

F R E C

ITEM#	QUANTITY	ITEM DESCRIPTION
1	5	SADDLE BAND
2	10	.375 x 5 JBOLT
3	10	.375 NUT

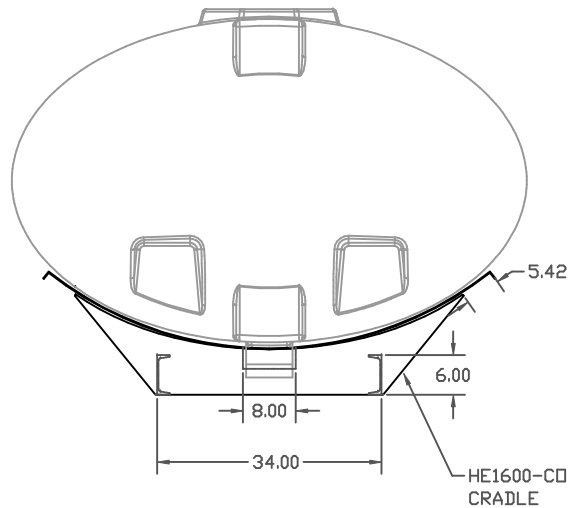
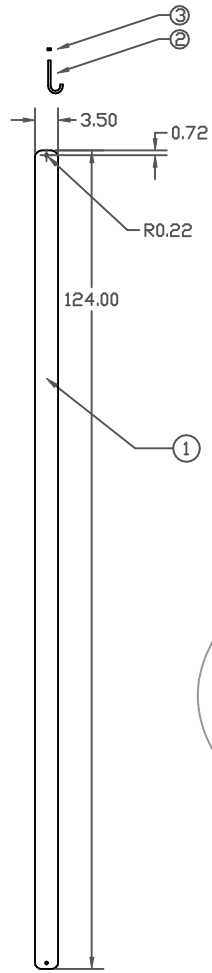

HE1600-SBPS  
BAND AND  
HDWE

10 GA 33x14.25  
C6 x 8.2 x 113.88  
10 GA 74x14.25  
7 GA

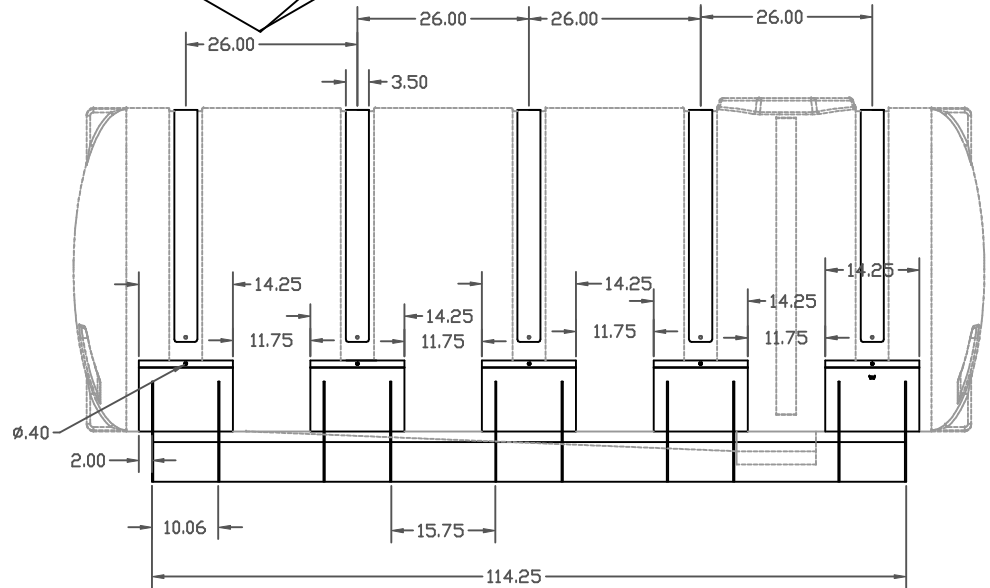
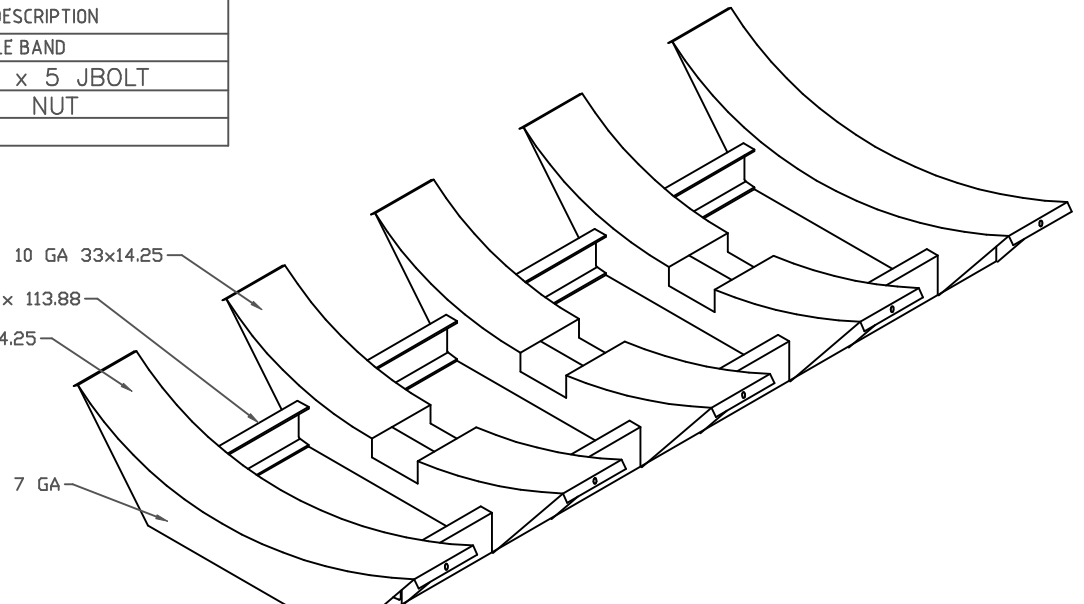

REV	DESCRIPTION	DATE	APPRD

DRAWN / DATE DHJ 9/20/06
APPRD. / DATE REH 2/5/07

MATERIAL  
STEEL

**CSI**  
ChemIndustrial Systems, Inc.  
PO Box 500, Cedarburg, WI 53012  
262-375-8570 • (Fax) 262-375-8559 • info@chemindustrial.com

ALL DIMENSIONS ARE IN DECIMAL INCHES  
TOLERANCES UNLESS OTHERWISE SPECIFIED  
± .125

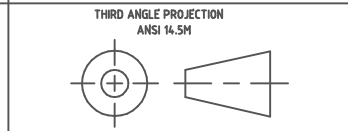

NOTES:  
POWDER COAT  
BLACK

SCALE  
N.S.

PART NO.